



# Ideal for fast material changes and quick color changes

Easily access the removable hoppers by quickly disconnecting the mounting bracket.

### 100 series

The WSB 140R consists of 1 hopper with 2 material compartments and 2 removable hoppers. Ideal for injection molders and small extruders with throughputs up to 450 lb/hr (205 kg/hr).

### Mounting bracket with quick release connections

The unit comes with an optional receiver support mounting bracket for the removable hoppers. This mounting bracket comes with quick release connections so operators can quickly access the removable hoppers for fast material changes and clean out.

### Easy cleanout

The removable hoppers are quick and easy to remove and are designed with hinged lids for easy cleanout.

### Wide range of settings

Each main material is dosed by a stainless steel slide gate. The slide gate is capable of dosing a wide range of settings, from as little as 1% to 100%, based on an average density free flowing material (0.65). Each removable hopper uses a pivot valve for dosing additives and masterbatches.

### Quick color changes

With no bolts or tools required, the removable hoppers are ideal for quick color or additive changes, reducing downtime.

### Lightweight removable hoppers

The removable hoppers have an integrated dispense valve, eliminating material spillage and ensuring easy cleanout.

### Batch size

The hoppers and augers are mounted above the weigh bin with a default 2.2 lb (1 kg) batch size.

### High consistent accuracy

On every material within  $\pm 0.1\%$  on a 1% setting.

### Sequential dispensing

The system tares the weight of the weigh bin and then each material is dispensed – Regrind, Natural, Color and Additive – in sequence to ensure accurate dispenses of every material within the blend.

### Homogenous mix

A complete batch is released into the mixing chamber and mixed with the previous batch to ensure a homogenous mix.



### Control of the mix

Material blending is controlled by a level sensor mounted in the upper part of the mix chamber to retain accurate mixing. When the sensor is covered, the blender will not dispense any further batches.

### Easy set up

Settings are made easily by either user friendly thumbwheels or entering settings directly on the keypad / optional touchscreen.

### Password protection

Special functions can be easily accessed and set via the password protect key.

### Audible and visual alarms

An audible and visual alarm sounds should a batch be incomplete.

### Reporting

Setup and operation reports can be printed direct to a USB key. Alternatively, data is also available via Ethernet or serial ports allowing remote access and monitoring.

### Quick cleanout

A compressed air gun is provided for quick cleanout.

### Controller

The Maguire controller monitors and confirms the weight of each ingredient and comes with an optional touchscreen.



# WSB 140R Gravimetric Blender Dimensions

Compartments 1 & 2 - 1.2 cu ft [34 Litres]  
Compartments 3 & 4 - 0.5 cu ft [14 Litres]

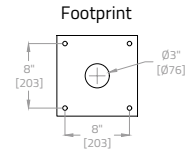
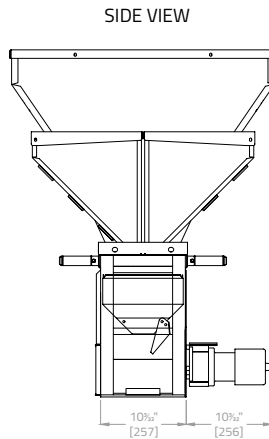
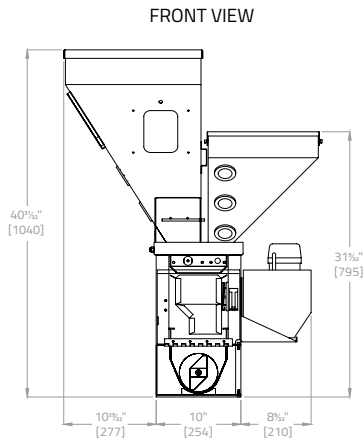

STD WSB Bottom Plate  
1/2" [6.4] Steel Plate

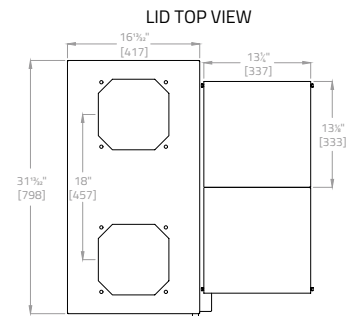

## Technical data

Model WSB 140R	
Maximum Throughput*	148kg/h to 205kg/h 325lb/h to 450lb/h
Number of Materials	4
Material Dispense Systems	2 - 1.5"x 3" Slide gate 2 - 1" Pivot valve
Weight	86kg 190lb
Power Supply	120vac - 4.8 Amp 230vac - 2.5 Amp
Operating Air Pressure	4-6 Bar 60-90psi
Air Consumption	0.3 m³/hr 0.17cfm
Shipping Weight	102Kg 225lb
H x W x D	122 x 85 x 85cm 48 x 33.5 x 33.5in

\*Throughput achieved is influenced by number of materials, how well they flow, vibration and loading consistency - each can effect maximum output of a blender, which in turn effects sizing the correct blender required for an application.

## Key features

- Ideal for small processing machines
- Reduced weight and footprint
- Overall precision of ±0.1% of specified blend
- Compressed air gun for quick cleanout included
- Easy access to all material contact surfaces of the machine including hoppers, weigh bin, and mixing chamber permits rapid colour change without the use of tools
- Proprietary microprocessor-control technology monitors and confirms the weight of each ingredient / touch-screen optional.
- Compensation is made when a variation in dispense weight is detected
- Vibration Weighing management
- Improved documentation capabilities
- 5 Year Warranty



Maguire reserves the right to cancel product or change product, product specifications and data without notice to improve reliability, function, design or otherwise.

### MAGUIRE WORLDWIDE DISTRIBUTION LOCATIONS

#### Maguire USA

Aston, PA, USA  
T: +1 610 459 4300  
F: +1 610 459 2700  
E: info@maguire.com

#### Maguire Canada

Ontario, Canada  
T: +1 905 879 1100  
F: +1 905 879 1101  
E: info@maguirecanada.com

#### Maguire Europe

Staffordshire, UK  
T: +44 1827 338 280  
F: +44 1827 338 285  
E: info@maguire-europe.com

#### Maguire IMEA

Dubai, UAE  
T: +971 4 881 6700  
E: info@maguire-imea.com

#### Maguire Asia

Singapore  
T: +65 6848 7117  
F: +65 6542 8577  
E: magasia@maguire-products.com.sg

#### Maguire China

Shanghai  
T: +86 21 5882 3410  
F: +86 21 5882 3420  
E: amber@maguirechina.com

